

Drawing ID

ECW-S25X

Product Info.

Finish	Code
Polish	ECW-S25M
Satin	ECW-S25S
Texture Black	ECW-S25B

Side View

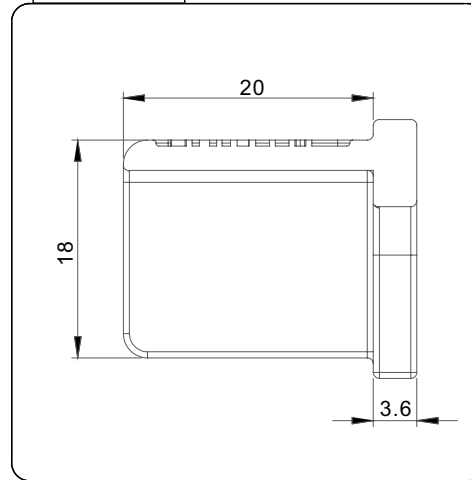

Back View

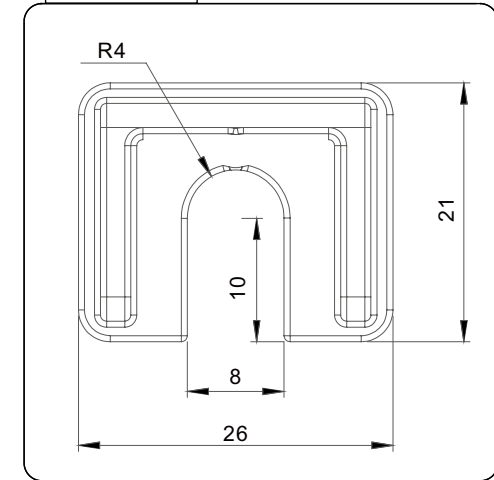

Instructions

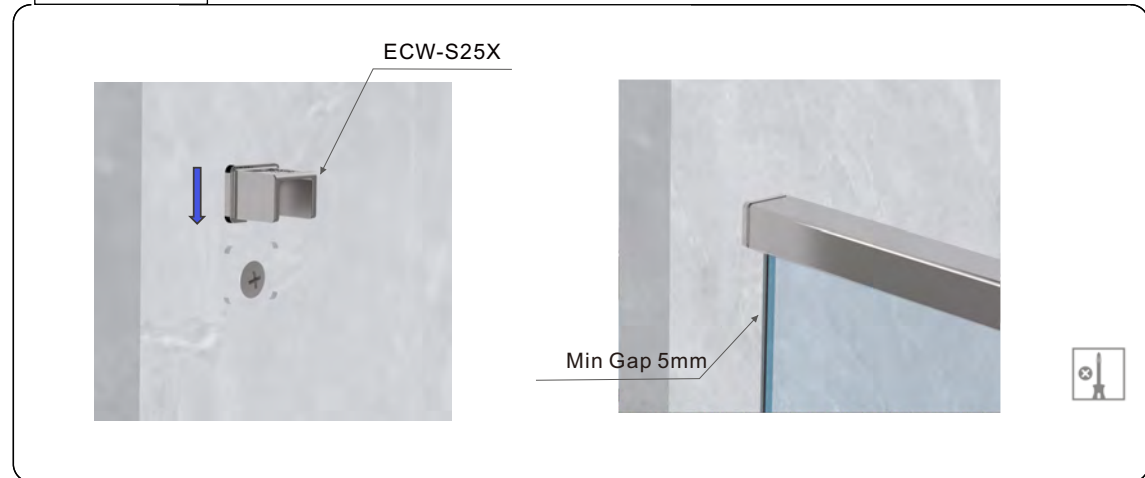

MATERIAL:

2205 Stainless Steel

CATALOGUE AND DESCRIPTION:

- > Railing Systems
- > TR-S25 Series
- > Conceal Wall Fix Wall Bracket

NOTES:

This drawing and or specification is the property of Silver Stone Hardware Pty Ltd - and must be returned to them on request. Unauthorised use may result in Legal Action. Its contents must not be made public, nor copied, nor used directly or indirectly in any way.

SILVER STONE HARDWARE PTYLID

56-62 Bryant Street, Padstow, NSW 2211
 T: (02) 9792 2955 M: 0452 526 680
www.silverstonehardware.com.au
sales@silverstonehardware.com.au